

Your Global Automation Partner

**TURCK**

# RU... Standard Ultrasonic Sensor

Instructions for Use



# Contents

<b>1</b>	<b>About These Instructions .....</b>	<b>5</b>
1.1	Target groups.....	5
1.2	Explanation of symbols used .....	5
1.3	Other documents .....	5
1.4	Feedback about these instructions.....	5
<b>2</b>	<b>Notes on the Product.....</b>	<b>6</b>
2.1	Product identification.....	6
2.2	Scope of delivery .....	6
2.3	Legal requirements .....	6
2.4	Turck service.....	6
<b>3</b>	<b>For Your Safety.....</b>	<b>7</b>
3.1	Intended use.....	7
3.2	Obvious misuse.....	7
3.3	General safety instructions.....	7
<b>4</b>	<b>Product Description .....</b>	<b>8</b>
4.1	Device overview .....	8
4.1.1	Indication elements .....	9
4.2	Properties and features.....	9
4.3	Operating principle.....	10
4.4	Functions and operating modes .....	11
4.4.1	Setting options .....	11
4.4.2	Diffuse mode sensor .....	11
4.4.3	Retroreflective mode.....	13
4.5	Technical accessories.....	14
<b>5</b>	<b>Installing.....</b>	<b>16</b>
<b>6</b>	<b>Connection.....</b>	<b>17</b>
6.1	Connection diagram .....	17
<b>7</b>	<b>Commissioning .....</b>	<b>18</b>
<b>8</b>	<b>Operation .....</b>	<b>19</b>
8.1	Operation as a diffuse mode sensor – LEDs .....	19
8.2	Operation as a retroreflective sensor – LEDs .....	19
<b>9</b>	<b>Setting .....</b>	<b>20</b>
9.1	Setting via teach adapter.....	21
9.2	Setting by manual bridging (shorting) .....	27
9.3	Setting via the pushbuttons.....	33
<b>10</b>	<b>Troubleshooting .....</b>	<b>39</b>
<b>11</b>	<b>Maintenance.....</b>	<b>40</b>

12	Repair .....	40
12.1	Returning devices.....	40
13	Disposal .....	40
14	Technical Data.....	41
14.1	Factory settings .....	42
15	Turck Subsidiaries - Contact Information .....	43

# 1 About These Instructions

These instructions for use describe the structure, functions and the use of the product and will help you to operate the product as intended. Read these instructions carefully before using the product. This is to avoid possible damage to persons, property or the device. Retain the instructions for future use during the service life of the product. If the product is passed on, pass on these instructions as well.

## 1.1 Target groups

These instructions are aimed at qualified personal and must be carefully read by anyone mounting, commissioning, operating, maintaining, dismantling or disposing of the device.

## 1.2 Explanation of symbols used

The following symbols are used in these instructions:



**DANGER**

DANGER indicates a dangerous situation with high risk of death or severe injury if not avoided.



**WARNING**

WARNING indicates a dangerous situation with medium risk of death or severe injury if not avoided.



**CAUTION**

CAUTION indicates a dangerous situation of medium risk which may result in minor or moderate injury if not avoided.



**NOTICE**

NOTICE indicates a situation which may lead to property damage if not avoided.



**NOTE**

NOTE indicates tips, recommendations and useful information on specific actions and facts. The notes simplify your work and help you to avoid additional work.



**CALL TO ACTION**

This symbol denotes actions that the user must carry out.



**RESULTS OF ACTION**

This symbol denotes relevant results of actions.

## 1.3 Other documents

Besides this document the following material can be found on the Internet at [www.turck.com](http://www.turck.com):

- Data sheet
- EU Declaration of Conformity (current version)

## 1.4 Feedback about these instructions

We make every effort to ensure that these instructions are as informative and as clear as possible. If you have any suggestions for improving the design or if some information is missing in the document, please send your suggestions to [techdoc@turck.com](mailto:techdoc@turck.com).

## 2 Notes on the Product

### 2.1 Product identification

**RU 130 U - M30 E - 2U P 8 X2 T - H1 1 5 1**

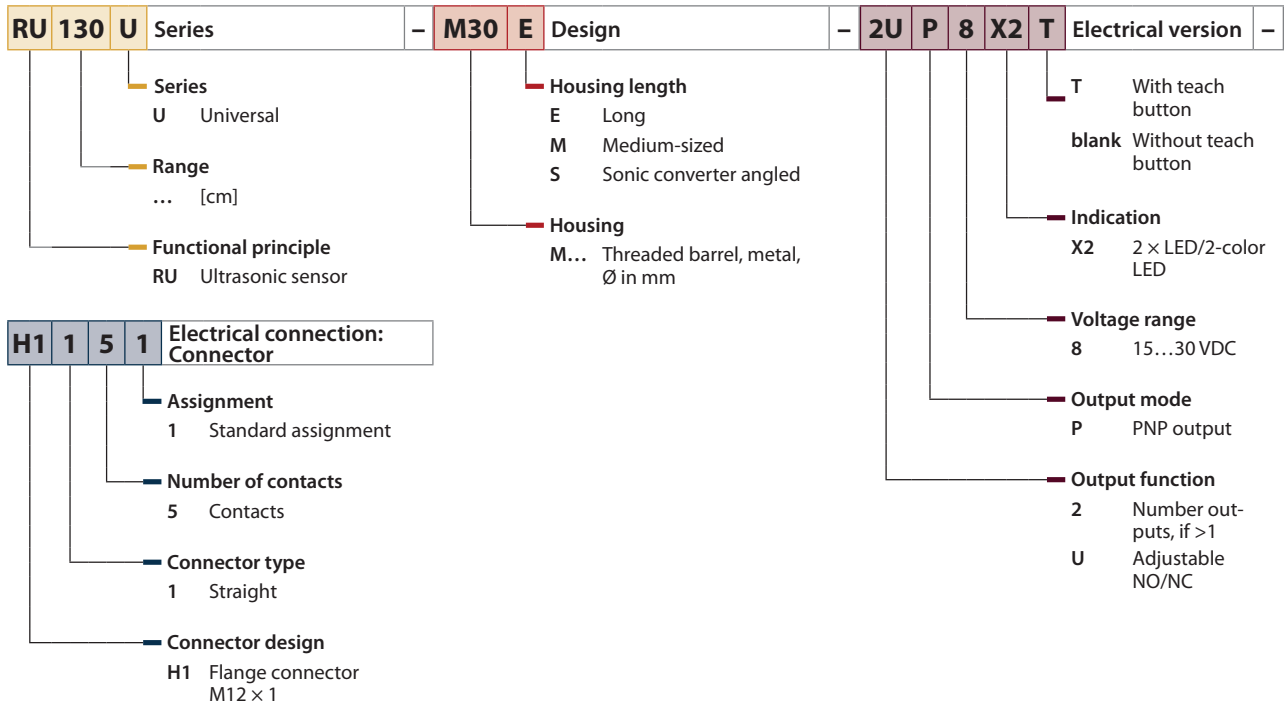

### 2.2 Scope of delivery

The scope of delivery includes:

- Ultrasonic sensor
- Two nuts for mounting
- Quick Start Guide

### 2.3 Legal requirements

The device is subject to the following EC directives:

- 2014/30/EU (electromagnetic compatibility)
- 2011/65/EU (RoHS Directive)

### 2.4 Turck service

Turck supports you with your projects, from initial analysis to the commissioning of your application. The Turck product database under [www.turck.com](http://www.turck.com) contains software tools for programming, configuration or commissioning, data sheets and CAD files in numerous export formats.

The contact details of Turck subsidiaries worldwide can be found on p. [▶ 43].

## 3 For Your Safety

The product is designed according to state-of-the-art technology. However, residual risks still exist. Observe the following warnings and safety notices to prevent damage to persons and property. Turck accepts no liability for damage caused by failure to observe these warning and safety notices.

### 3.1 Intended use

The ultrasonic sensors detect the presence of solid or liquid objects and the distance to those objects without making physical contact.

The devices may only be used as described in these instructions. Any other use is not in accordance with the intended use. Turck accepts no liability for any resulting damage.

### 3.2 Obvious misuse

- The devices are not safety components and must not be used for personal or property protection.

### 3.3 General safety instructions

- The device may only be assembled, installed, operated, parameterized and maintained by professionally-trained personnel.
- The device may only be used in accordance with applicable national and international regulations, standards and laws.
- Not all objects are detected equally well by the sensor. The detection of the object must be checked by the user prior to regular operation.
- Strong air movements can disturb the correct function of the sensor and corrupt the measured values. Avoid air currents between the sensor and the object to be detected.

## 4 Product Description

The devices are contained in a metal housing with an M18 or M30 male thread. The sonic transducer surface can be installed flush with the surrounding area.

All devices are provided with a metal M12 male connector for connecting the sensor cable. A switching distance can be set for object detection, which must be less than or equal to the maximum detection range, and greater than the minimum switching distance.

The devices can be set via the pushbuttons, teach adapters or by manual bridging, depending on the design.

The Standard ultrasonic sensors are available both without integrated operating elements and also with two setting buttons. The devices are provided with two programmable switching outputs that can be set as NO or NC contacts. The start and end point of the switch window can be set for both switching outputs. The switch window must be within the detection range. The devices can be used as diffuse mode or retroreflective sensors.

### 4.1 Device overview

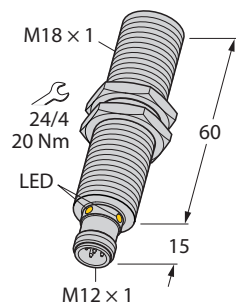

Fig. 1: RUxxU-M18E-2UP8X2-H1151  
(without teach button)

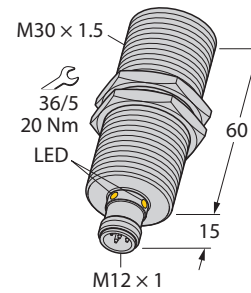

Fig. 2: RUxxU-M30M-2UPN8X2-H1151  
(without teach button)

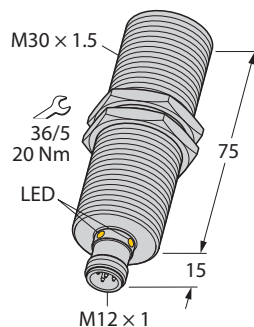

Fig. 3: RU300U-M30M-2UP8X2-H1151  
(without teach button)

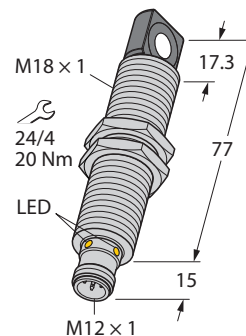

Fig. 4: RUxxxU-M18ES-2UP8X2-H1151



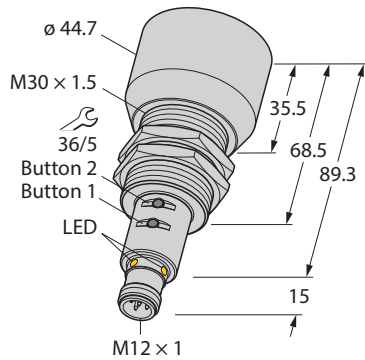

Fig. 5: RU600U-M30E-2UP8X2T-H1151

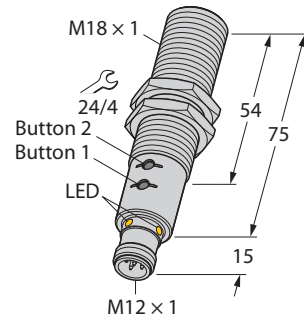

Fig. 6: RUxxU-M18E-2UPN8X2T-H1151

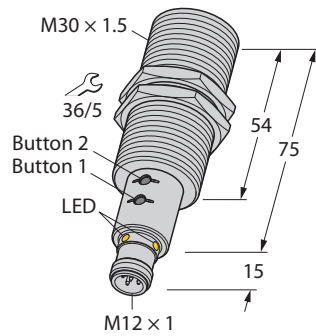

Fig. 7: RUxxU-M30E-2UPN8X2T-H1151

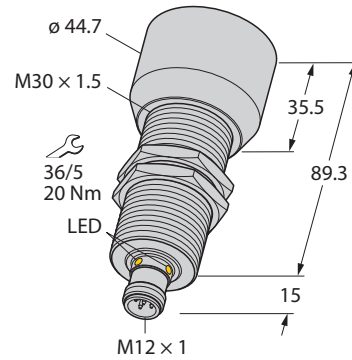

Fig. 8: RU600U-M30M-2UP8X2-H1151

#### 4.1.1 Indication elements

The ultrasonic sensors have a green and a yellow LED which are visible via four indication points. Only one LED can be active at one time. If an LED is active, all four indication points are lit.

#### 4.2 Properties and features

- Smooth sonic transducer front
- Cylindrical design, potted
- Temperature compensation
- M12 × 1 male connector
- Adjustable measuring range
- Two independent switching outputs

## 4.3 Operating principle

Ultrasonic sensors are designed for the non-contact and wear-free detection of a variety of targets by means of sound waves. It does not matter here whether the target is transparent or non-transparent, metallic or non-metallic, solid, liquid or in powder form. Environmental conditions such as spray, dust or rain also hardly affect the functioning of the sensors.

Ultrasonic sensors emit one or several ultrasonic pulses that are propagated in the air at the speed of sound. A part of the ultrasonic wave is reflected by the object. The sensor measures the total time of flight from the sensor to the object and back to the sensor. The distance to the object is then calculated with the following formula:

$$D = c \times t / 2$$

D Distance from the sensor to the object in m

c Speed of sound in air in m/s

t Time of flight for the ultrasonic pulse in s

To improve accuracy, the ultrasonic sensor forms the mean value from the measurement of several sound pulses before outputting a new value. The ultrasonic velocity depends on the composition and the temperature of the gas in which the sound is propagated. In most ultrasound applications, the composition of the gas is stable whereas the temperature may often fluctuate.

The speed of sound in air varies with the temperature according to the following approximation formula:

$$c_{\text{air}} = 20 \times \sqrt{(273 + T)}$$

$c_{\text{air}}$  Speed of sound in air in m/s

T Temperature in °C

The speed of sound at an air temperature of 20 °C is approximately 344 m/s

The following formula applies to sensors with integrated temperature compensation:

$$c_{\text{air}} = (331.5 \times 0.596 + T)$$

Fluctuations in air temperature affect the speed of sound, which in turn has an effect on the total time for the echo measured by the sensor. An increase in air temperature shifts both measuring range limits closer to the sensor and the time of flight of the echo is shorter. A drop in air temperature shifts both measuring range limits away from the sensor and the time of flight of the echo is longer. This shift is approximately 3.5 % of the limit distance with a temperature change of 20 °C.

Good ultrasonic reflectors are metals, glass, stone, wood with smooth and hard surfaces, as well as liquids that are aligned appropriately to the sensor. Cloth, sand or grains absorb some of the sonic energy. Foams and skins are particularly poor reflectors.

## 4.4 Functions and operating modes

The ultrasonic sensors are provided with two switching outputs that can be set independently of each other. The sensors can be operated as diffuse mode or retroreflective sensors during normal operation. The user can set an individual switch point as well as a window or hysteresis function.

When used in diffuse mode, either a single switch point or a switch window is defined. The switch window is used for window or hysteresis functions. When used as a retroreflective sensor, switching output 2 is switched on. A small switch window is taught in. The behavior of switching output 1 is inverted in relation to switching output 2.

When using the hysteresis function, a switching range is taught in that is defined by two switch points.

### 4.4.1 Setting options

The devices feature the following three setting options:

- Setting by manual bridging (shorting)
- Setting with connected teach adapter (accessories to be ordered separately)
- Setting via the pushbuttons

### 4.4.2 Diffuse mode sensor

The diffuse mode is the standard operating mode of most ultrasonic sensors. The sensor detects the required object via the echo of the ultrasonic waves. The distance to an object is determined from the time of flight. Any additional wiring or accessories are not required.

When using diffuse mode sensors, a switching point or switch window is defined. The switch window is used for window or hysteresis functions.

#### Diffuse mode sensor with NC function

When used as a diffuse mode sensor with an NC function, a switching point is taught in for a switch output. The output behaves as follows:

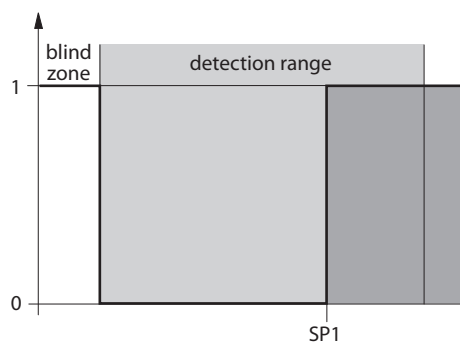

Fig. 9: Diffuse mode sensor with NC function – Behavior of the switching output

### Diffuse mode sensor with NO function

When used a diffuse mode sensor with an NO function, a switching point is taught in for a switch output. The output behaves as follows:

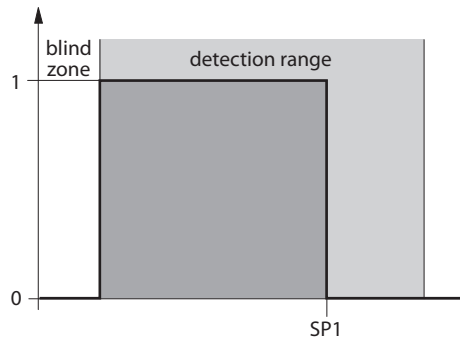

Fig. 10: Diffuse mode sensor with NO function – Behavior of the switching output

### Window function

The start and end point of the switch window range can be set for the outputs. The switch window must be within the detection range.

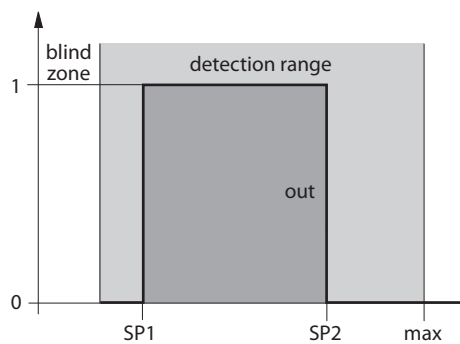

Fig. 11: Window function – Behavior of the switching output

### Hysteresis function

When using the hysteresis function, a switch window is taught in that is defined by two switching points. The switching outputs have the following behavior as outputs:

If an object is moved away from the sensor, the switching output is switched on for as long as the object is located between the beginning of the detection range and switching point 2. If the object passes switching point 2, the switching output is switched off. If an object is moved towards the sensor, the switching output is switched off for as long as the object is located between the beginning of the detection range and switching point 1. If the object passes switching point 1, the switching output is switched on.

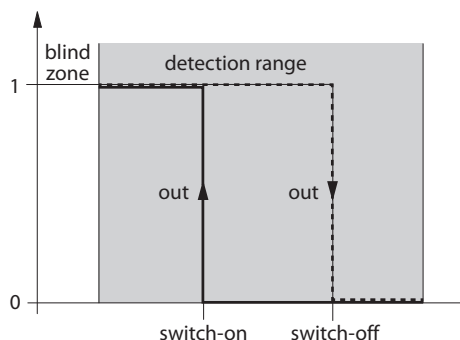

Fig. 12: Hysteresis function – behavior of switching output

#### 4.4.3 Retroreflective mode

When used as a retroreflective sensor, the sensor detects the echo of the ultrasonic waves of the taught reflector. The reflector can be any object with a surface that is as smooth as possible. The sensor generates a short switching window around the position of the reflector and detects the echo. The sensor switches if the echo is blocked or deflected by another object.

This operating mode is normally more reliable than the diffuse mode and is particularly suitable for objects that are difficult to detect and in difficult ambient conditions.

Any additional wiring or accessories are not required.

Synchronization with other sensors is not possible in this operating mode.

When used as a retroreflective sensor switching output 2 is switched on. The behavior of switching output 1 is inverted in relation to switching output 2.

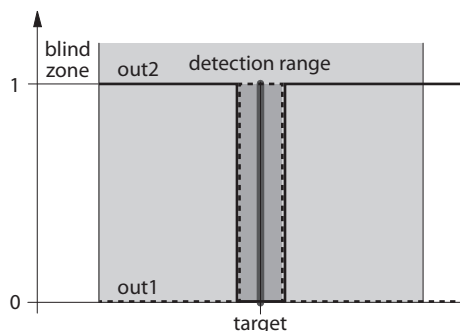

Fig. 13: Retroreflective mode – behavior of the switching output

## 4.5 Technical accessories

The following accessories are supplied with the device:

Dimension drawing	Type	Ident-No.	Description
	TX1-Q20L60	6967114	Teach adapter
	RKC4.5-2/ TEL	6625016	Connection cable, M12 female connector, straight, 5-pin, cable length: 2 m, sheathing material: PVC, black; cULus approval; other cable lengths and types available, see <a href="http://www.turck.com">www.turck.com</a>
	WKC4.5T-2/ TEL	6625028	Connection cable, M12 female connector, angled, 5-pin, cable length: 2 m, sheathing material: PVC, black; cULus approval; other cable lengths and types available, see <a href="http://www.turck.com">www.turck.com</a>
	MW-18	6945004	Mounting bracket, stainless steel, for M18

**Dimension drawing**

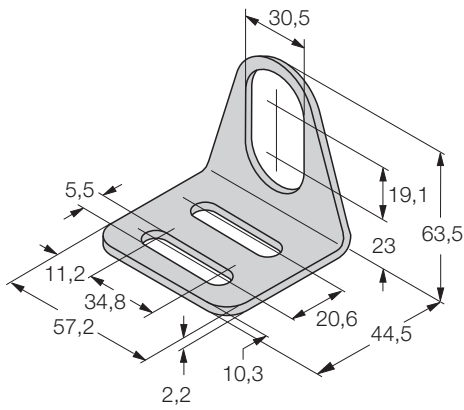

**Type**

MW-30

**Ident-No.**

6945005

**Description**

Mounting bracket, stainless steel, for M30

In addition to the above connection cables, Turck also offers other cable types for specific applications with the correct terminals for the device. More information on this is available from the Turck product database at [www.turck.de/products](http://www.turck.de/products) in the Connectivity area.

## 5 Installing



### NOTE

If using more than one ultrasonic sensor in an application: Avoid overlapping of sonic cones.

Overlapping can occur when two sensors are mounted less than 200 mm (RU40...), 450 mm (RU130...), 1000 mm (RU300...) or 2000mm (RU600...) apart.

The sensors can be mounted in any direction. The maximum tightening torque for fastening the sensors is 20 Nm.

- ▶ Clean the mounting surface and its surroundings.
- ▶ When using a mounting aid: Fasten the sensor in the mounting aid.
- ▶ Install the sensor or mounting aid at the intended position.
- ▶ Ensure that the rear plug connector is accessible.
- ▶ Mount the sensor so that the blind zone is clear of any relevant objects (see wave patterns or technical data).

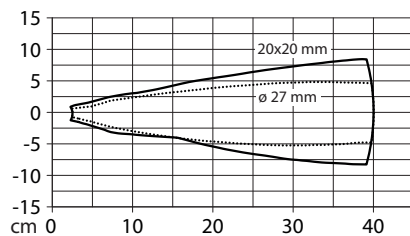

Fig. 14: RU40... wave pattern

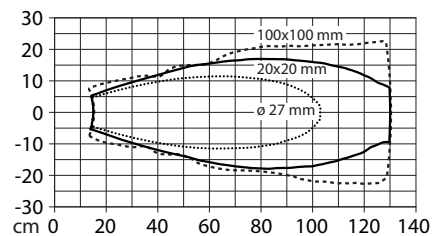

Fig. 15: RU130... wave pattern

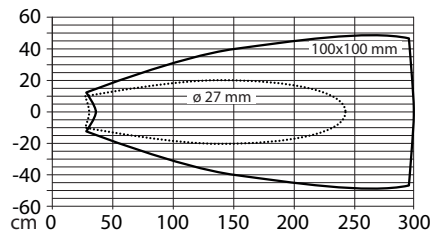

Fig. 16: RU300... wave pattern

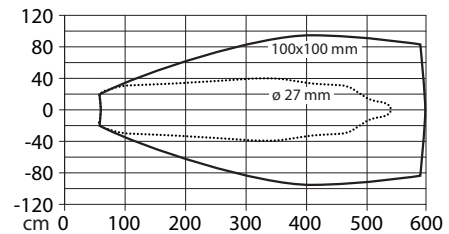

Fig. 17: RU600... wave pattern



## 6 Connection

- ▶ Connect the female connector of the connection cable to the male connector of the sensor.
- ▶ Connect the open end of the connection cable to the power supply and/or processing units.

### 6.1 Connection diagram

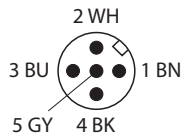

Fig. 18: Pin assignment

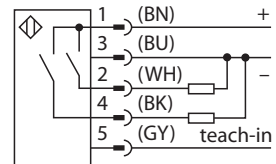

Fig. 19: Wiring diagram

## 7 Commissioning

The device is operational automatically once the cables are connected and the power supply is switched on.

## 8 Operation



### NOTICE

Incorrect use of the sensor

#### Possible damage to property due to malfunction

- ▶ Prevent the accumulation of material deposits on the surface of the sonic transducer.
- ▶ Keep the blind zone of the sensor clear. Refer to the technical data for the blind zone  $S_{min}$  of the sensor.

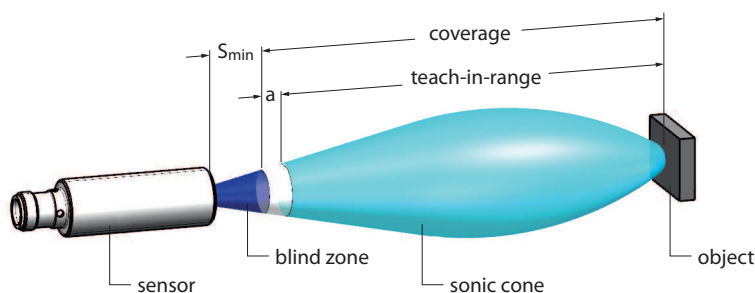

Fig. 20: Sonic cone and spread of the blind zone (schematic)

### 8.1 Operation as a diffuse mode sensor – LEDs

In diffuse mode the LEDs have the following indication functions:

LED indication	Meaning
Yellow	NO contact: Object within the teach-in range, switching output 1 on NC contact: No object in teach range, switching output 1 on
Green	NO contact: Object within the detection range, switching output 1 off NC contact: Object within the teach-in range, switching output 1 off
Off (only NO contact)	No object within the detection range, switching output 1 off

### 8.2 Operation as a retroreflective sensor – LEDs

In retroreflective mode the LEDs have the following indication functions:

LED	Meaning
Yellow	Reflector present, switching output 1 on
Green	Object between sensor and reflector, switching output 1 off
Off	No object within the detection range, switching output 1 off

Switching output 2 inverts the signal of switching output 1.

## 9 Setting

The ultrasonic sensor has switching outputs with separately adjustable switching points. The user can set a single switching point. The double switching point is used for a window or hysteresis function. The output behavior of the switching outputs is shown in the section Function and operating modes. The sensor switches automatically to normal operation after the teach-in operation is successfully completed.

	Teach-in to GND	Teach-in to $U_B$
Teach adapter	Press the pushbutton to GND	Press the pushbutton to $U_B$
Manual bridging (shorting)	Bridge pin 3 (BU) with pin 5 (GY)	Bridge pin 1 (BN) with pin 5 (GY)
Pushbutton on the device	Press pushbutton 1	Press pushbutton 2

The TX1-Q20L60 teach adapter is not included in the scope of delivery. To use the teach adapter connect it between the sensor and the connection cable.

Aborting the teach-in operation: Teach-in  $U_B$  for at least 2 s.

## 9.1 Setting via teach adapter

### Selecting the output

- ▶ Select switching output 1: Press and hold down the pushbutton on the adapter to GND for 2...7 s.
- ▶ Select output 2: Press and hold down the pushbutton on the adapter to GND for 8...13 s.

### Setting the switching point

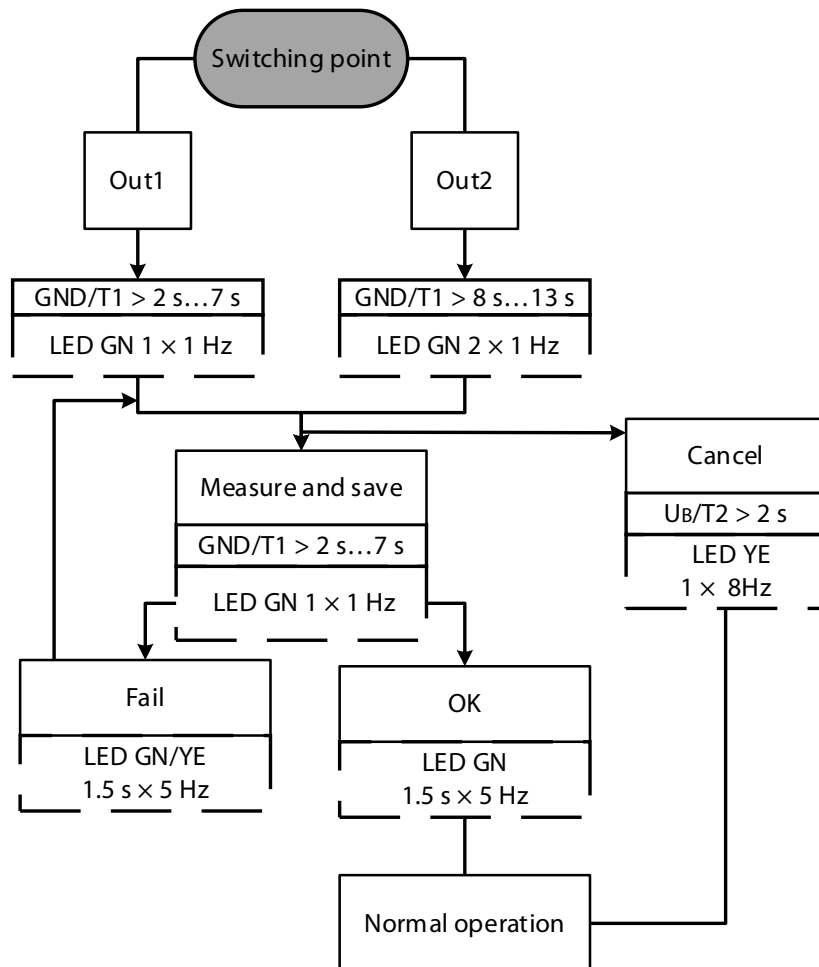

Fig. 21: Setting the switching point

- ▶ Connect the TX1-Q20L60 teach adapter between the sensor and the connection cable.
- ▶ Select the switching output.
- ▶ Position the object for the switching point.
- ▶ Store the switching point: Press and hold down the pushbutton on the adapter to GND for 2...7 s.
- ⇒ The individual switching point has been taught in successfully if the green LED flashes for 1.5 s at a frequency of 5 Hz.

## Window function – setting the switching range

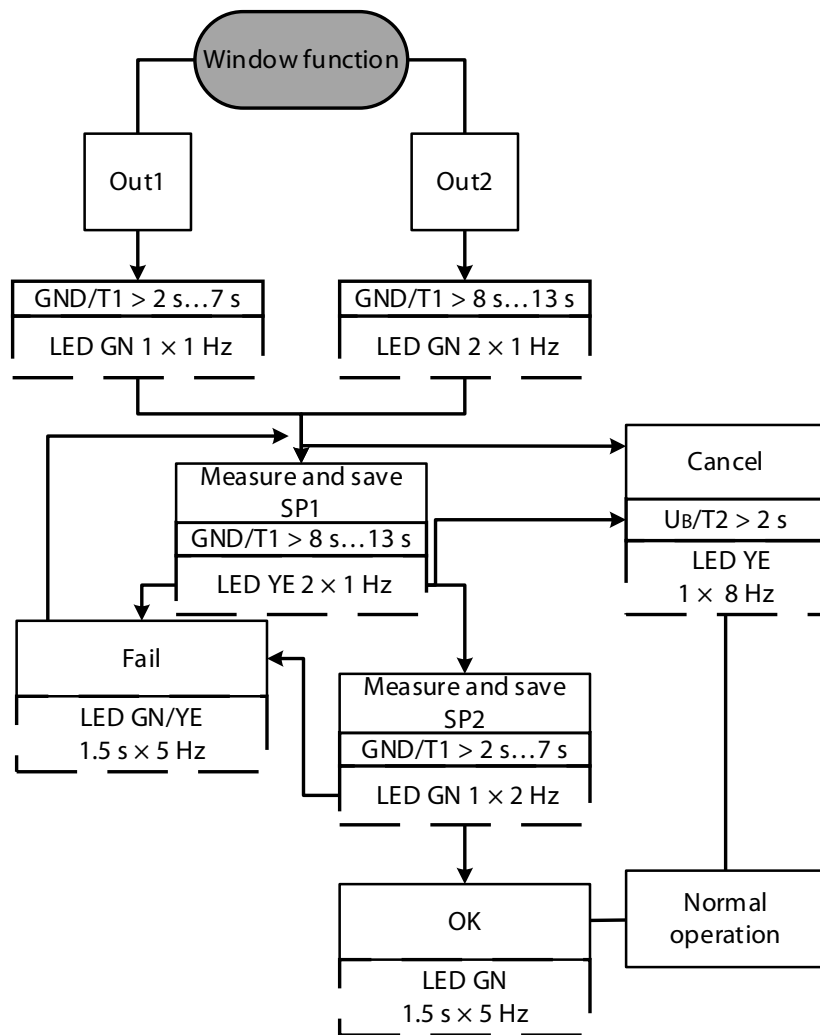

Fig. 22: Window function – setting the switching range

- ▶ Connect the TX1-Q20L60 teach adapter between the sensor and the connection cable.
- ▶ Position the object for switching point 1.
- ▶ Select the switching output.
- ▶ Store switching point 1: Press and hold down the pushbutton on the adapter to GND for 8...13 s.
- ▶ Position the object for switching point 2.
- ▶ Store switching point 2: Press and hold down the pushbutton on the adapter to GND for 2...7 s.
- ⇒ The switching points have been successfully taught in if the green LED flashes for 1.5 s at a frequency of 5 Hz.

Window function – switching between hysteresis and window

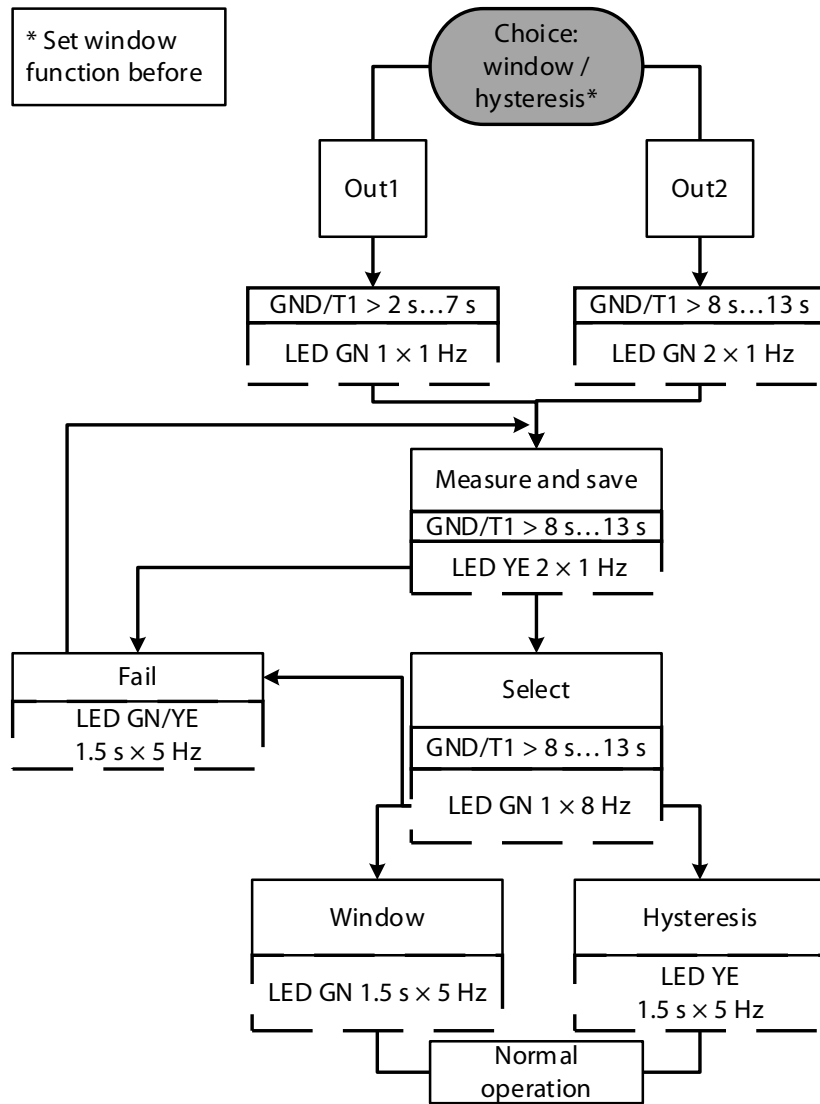

Fig. 23: Window function – switching between hysteresis and window

- ▶ Connect the TX1-Q20L60 teach adapter between the sensor and the connection cable.
- ▶ Select the switching output.
- ▶ Press and hold down the pushbutton on the adapter to GND for 14...19 s.
- ⇒ The output function has been successfully inverted as an NO contact if the green LED flashes for 1.5 s at a frequency of 5 Hz.
- ⇒ The output function has been successfully inverted as an NC contact if the yellow LED flashes for 1.5 s at a frequency of 5 Hz.

### Inverting the output function (NO/NC)

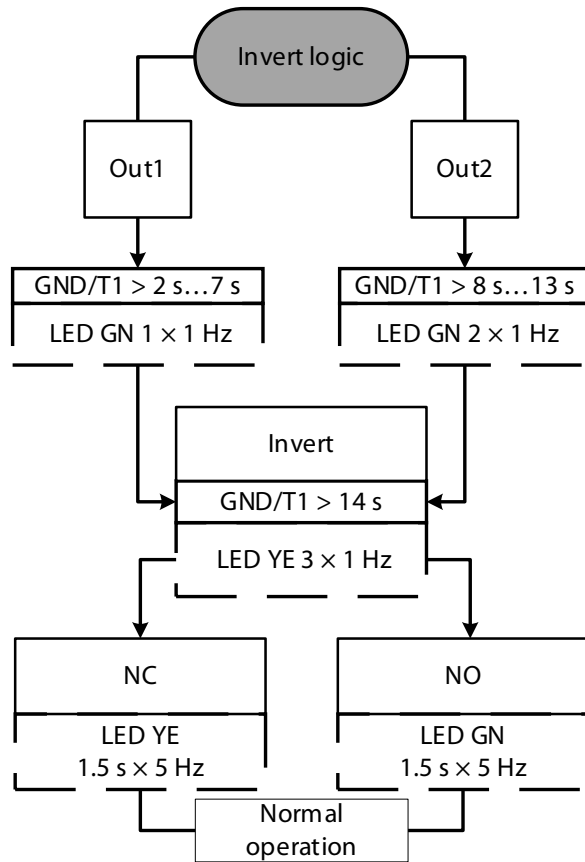

Fig. 24: Inverting the output function (NO/NC)

- ▶ Connect the TX1-Q20L60 teach adapter between the sensor and the connection cable.
- ▶ Select the switching output.
- ▶ Press and hold down the pushbutton on the adapter to GND for 14...19 s.
- ⇒ The output function has been successfully inverted as an NO contact if the green LED flashes for 1.5 s at a frequency of 5 Hz.
- ⇒ The output function has been successfully inverted as an NC contact if the green LED flashes for 1.5 s at a frequency of 5 Hz.



## Setting operation as a retroreflective sensor

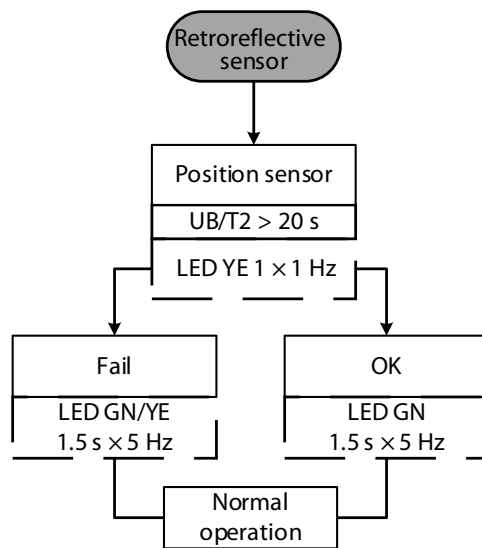

Fig. 25: Setting operation as a retroreflective sensor

- ▶ Connect the TX1-Q20L60 teach adapter between the sensor and the connection cable.
- ▶ Position the reflector within the detection range.
- ▶ Press and hold down the pushbutton on the adapter to  $U_b$  for at least 21 s.
- ⇒ The sensor is set successfully as a retroreflective sensor if the green LED flashes for 1.5 s at a frequency of 5 Hz.

## Reset to factory settings

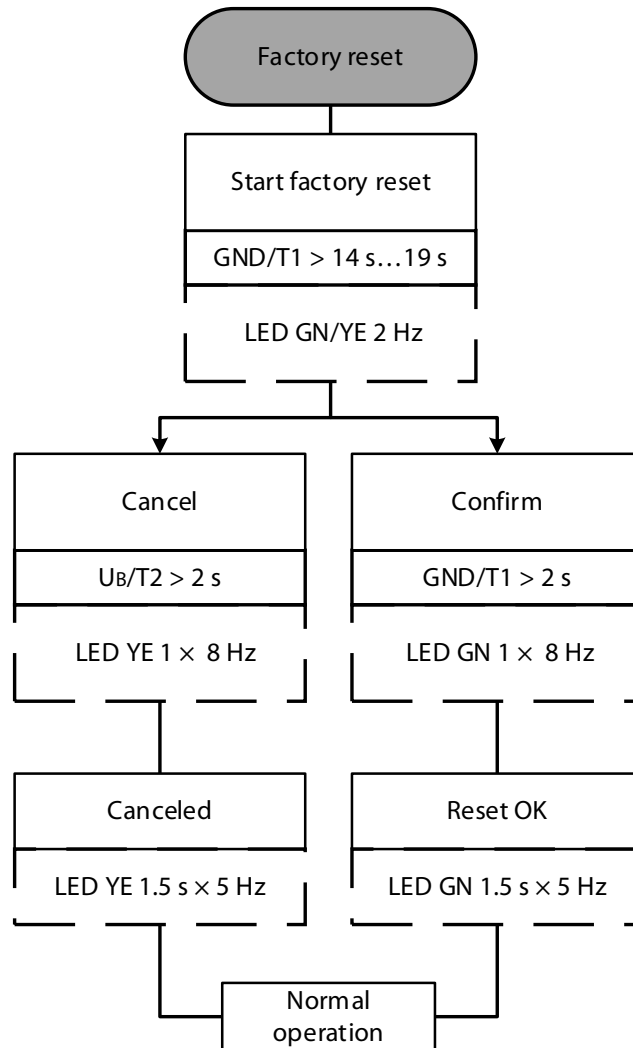

Fig. 26: Reset to factory settings

- ▶ Connect the TX1-Q20L60 teach adapter between the sensor and the connection cable.
- ▶ Starting the reset to factory settings: Press and hold down the pushbutton on the adapter to GND for 14...19 s.
- ▶ Confirming the reset to factory settings: Press and hold down the pushbutton on the adapter to GND for 2...7 s.
- ⇒ The device has been successfully reset to the factory settings if the green LED flashes for 1.5 s at a frequency of 5 Hz.

## 9.2 Setting by manual bridging (shorting)

Selecting the output

- ▶ Select switching output 1: Bridge pin 3 (BU) with pin 5 (GY) for 2...7 s.
- ▶ Select output 2: Bridge pin 3 (BU) with pin 5 (GY) for 8...13 s.

Setting the switching point

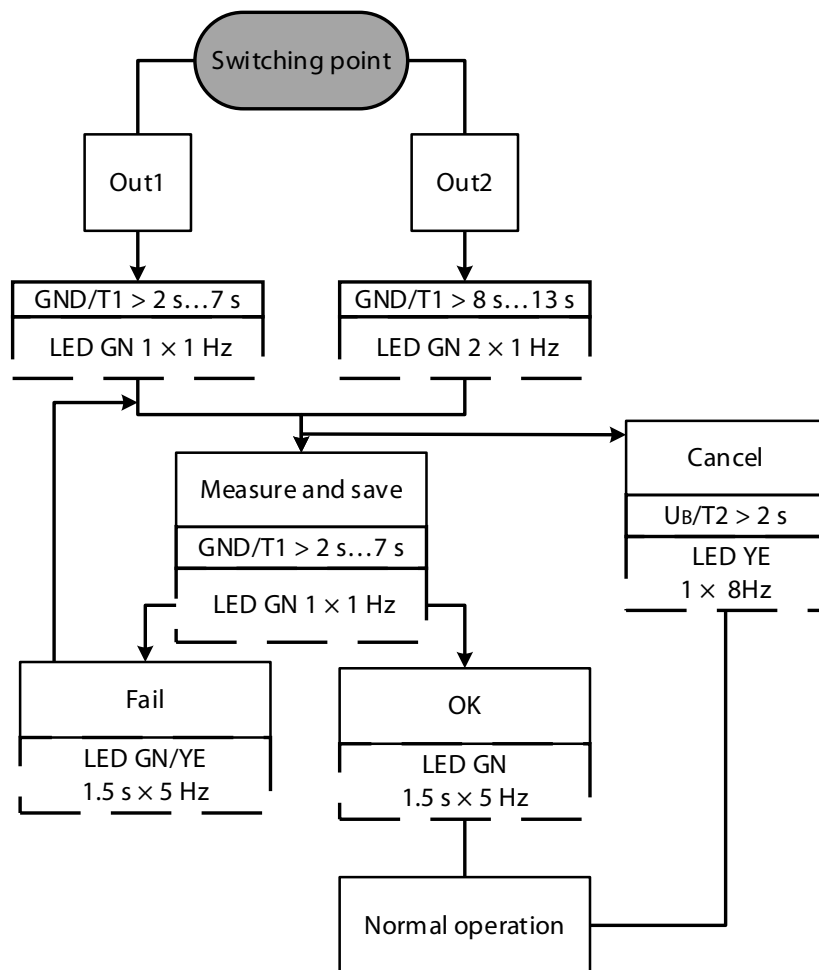

Fig. 27: Setting the switching point

- ▶ Select the switching output.
- ▶ Position the object for the switching point.
- ▶ Store the switching point: Bridge pin 3 (BU) with pin 5 (GY) for 2...7 s.
- ⇒ The individual switching point has been taught in successfully if the green LED flashes for 1.5 s at a frequency of 5 Hz.

Window function – setting the switching range

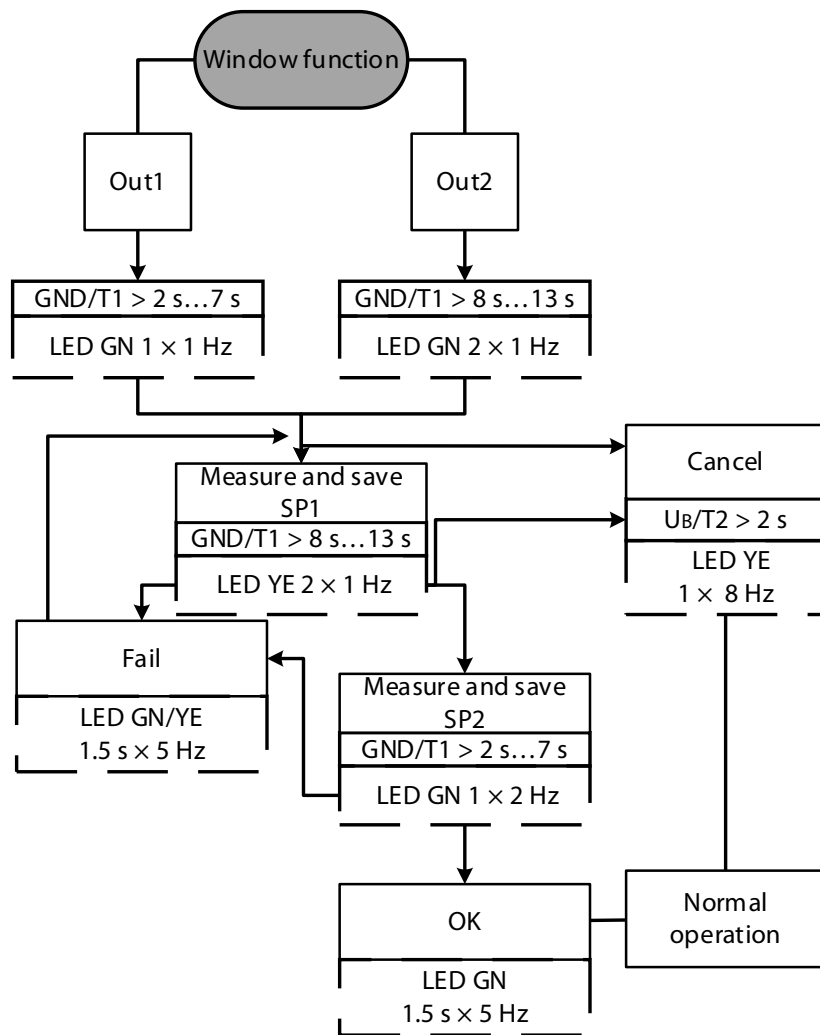

Fig. 28: Window function – setting the switching range

- ▶ Position the object for switching point 1.
- ▶ Store switching point 1: Bridge pin 3 (BU) with pin 5 (GY) for 8...13 s.
- ▶ Position the object for switching point 2.
- ▶ Store switching point 2: Bridge pin 3 (BU) with pin 5 (GY) for 2...7 s.
- ⇒ The switching points have been successfully taught in if the green LED flashes for 1.5 s at a frequency of 5 Hz.

Window function – switching between hysteresis and window

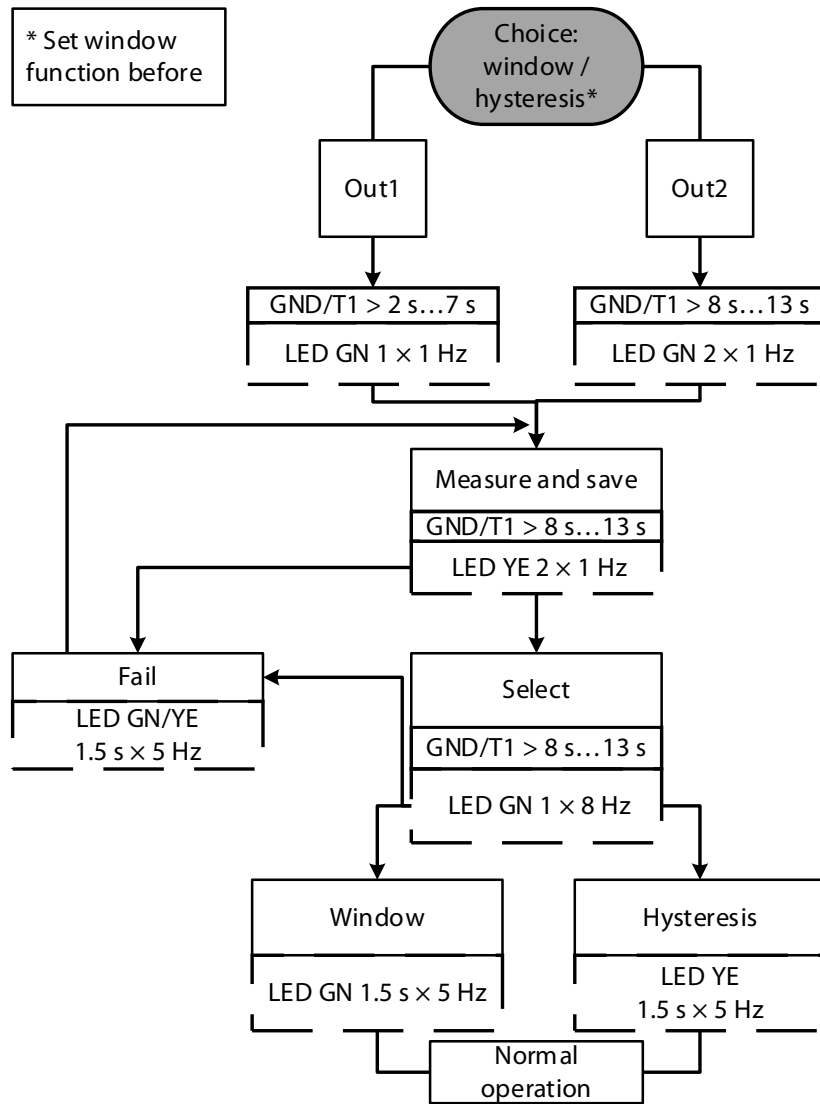

Fig. 29: Window function – switching between hysteresis and window

- ▶ Position the object at any point in the detection range.
- ▶ Bridge pin 3 (BU) with pin 5 (GY) for 14...19 s.
- ⇒ The output function has been successfully inverted as an NO contact if the green LED flashes for 1.5 s at a frequency of 5 Hz.
- ⇒ The output function has been successfully inverted as an NC contact if the yellow LED flashes for 1.5 s at a frequency of 5 Hz.

### Inverting the output function (NO/NC)

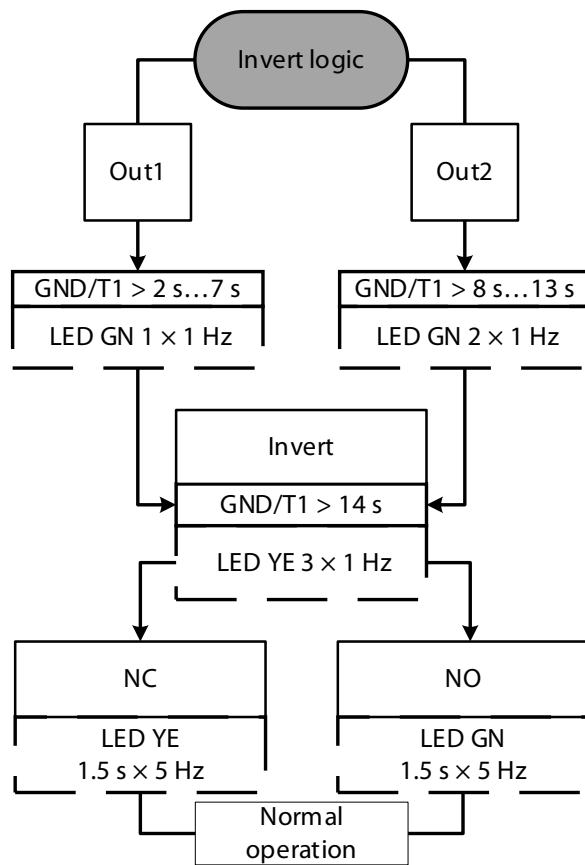

Fig. 30: Inverting the output function (NO/NC)

- ▶ Select the switching output.
- ▶ Bridge Pin 3 (BU) with Pin 5 (GY) for 14...19 s.
- ⇒ The output function has been successfully inverted as an NO contact if the green LED flashes for 1.5 s at a frequency of 5 Hz.
- ⇒ The output function has been successfully inverted as an NC contact if the green LED flashes for 1.5 s at a frequency of 5 Hz.

Setting operation as a retroreflective sensor

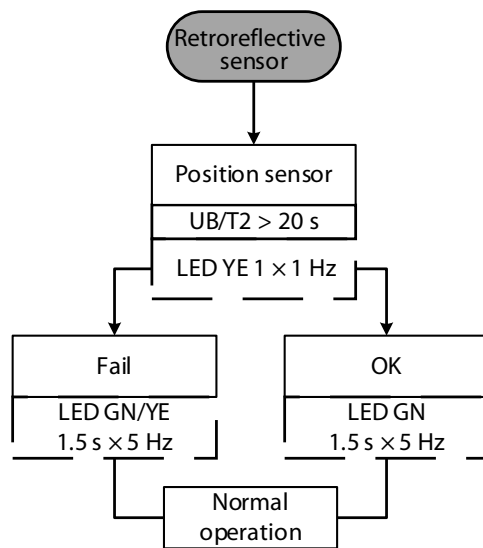

Fig. 31: Setting operation as a retroreflective sensor

- ▶ Position the reflector in the detection range.
- ▶ Bridge pin 1 (BN) with pin 5 (GY) for at least 21 s.
- ⇒ The sensor is set successfully as a retroreflective sensor if the green LED flashes for 1.5 s at a frequency of 5 Hz.

## Reset to factory settings

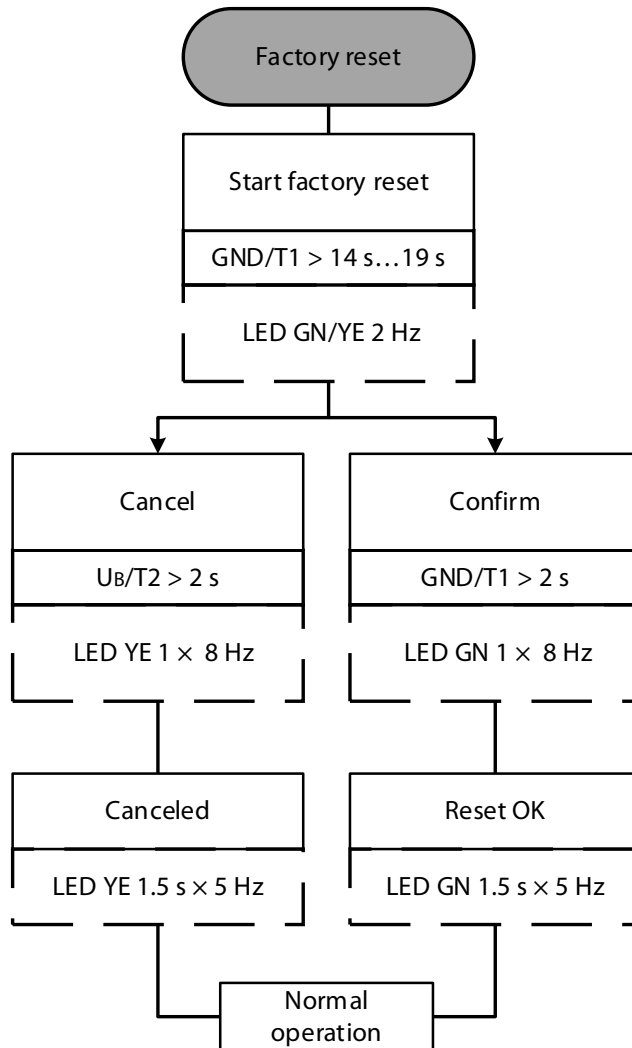

Fig. 32: Reset to factory settings

- ▶ Starting the reset to factory settings: Bridge pin 3 (BU) with pin 5 (GY) for 14...19 s.
- ▶ Confirming the reset to factory settings: Bridge pin 3 (BU) with pin 5 (GY) for 2...7 s.
- ⇒ The device has been successfully reset to the factory settings if the green LED flashes for 1.5 s at a frequency of 5 Hz.



### 9.3 Setting via the pushbuttons



**NOTE**

The devices with a teach button are ready for teaching in up to 300 s after the power supply is switched on. The teach button is then automatically locked. A new teach-in operation is only possible after the power supply has been reset.

#### Selecting the output

- ▶ Select switching output 1: Press and hold down pushbutton 1 for 2...7 s.
- ▶ Select output 2: Press and hold down pushbutton 1 for 8...13 s.

#### Setting the switching point

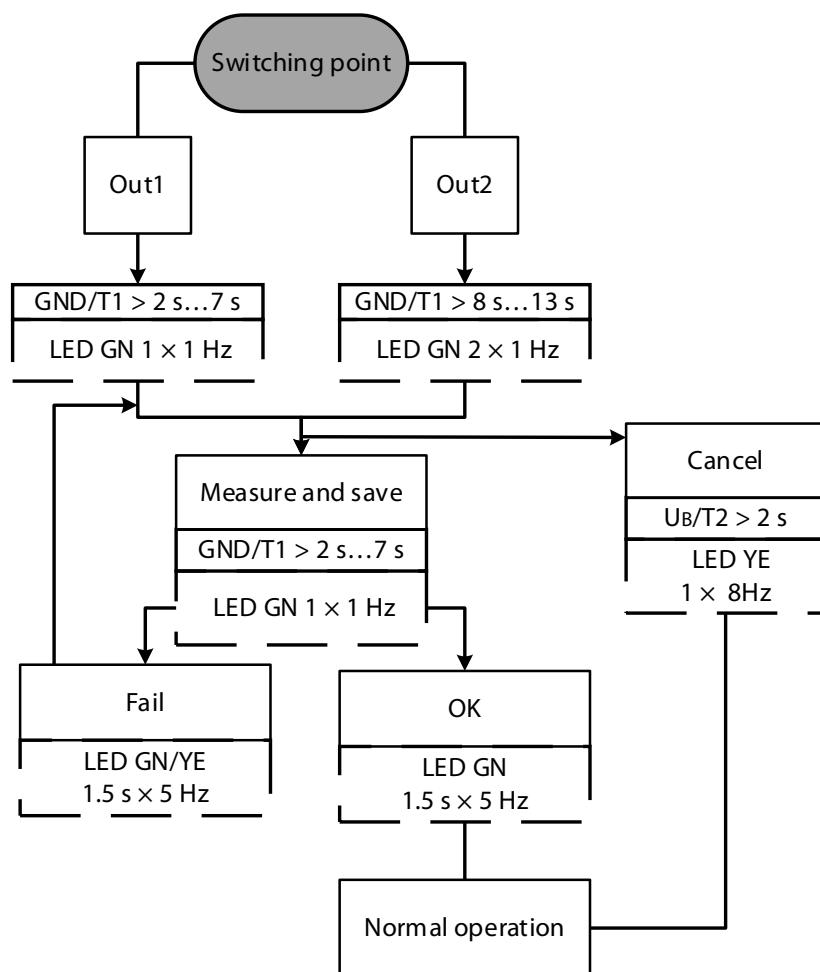

Fig. 33: Setting the switching point

- ▶ Select the switching output.
- ▶ Position the object for the switching point.
- ▶ Save the switching point: Press and hold down pushbutton 1 for 2...7 s.
- ⇒ The individual switching point has been taught successfully if the green LED flashes for 1.5 s at a frequency of 5 Hz.

Window function – setting the switching range

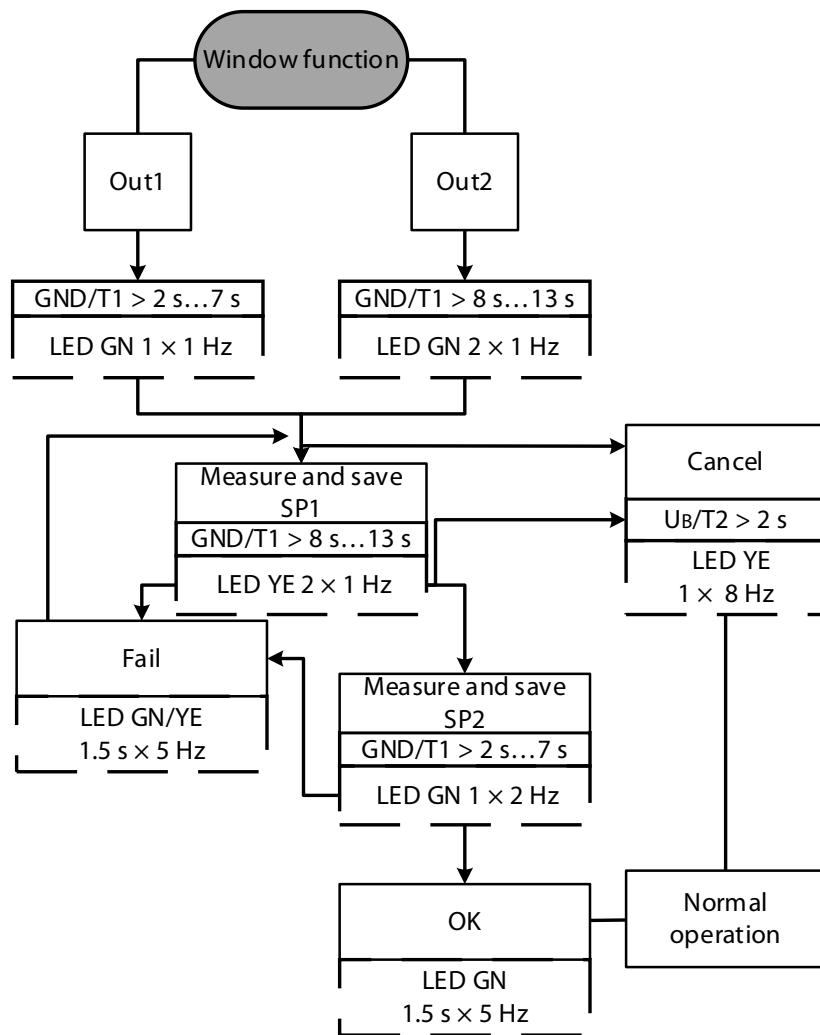

Fig. 34: Window function – setting the switching range

- ▶ Position the object for switching point 1.
- ▶ Select the switching output.
- ▶ Store switching point 1: Press and hold down pushbutton 1 for 8...13 s.
- ▶ Position the object for switching point 2.
- ▶ Store switching point 2: Press and hold down pushbutton 1 for 2...7 s.
- ⇒ The switching points have been successfully taught if the green LED flashes for 1.5 s at a frequency of 5 Hz.

Window function – switching between hysteresis and window

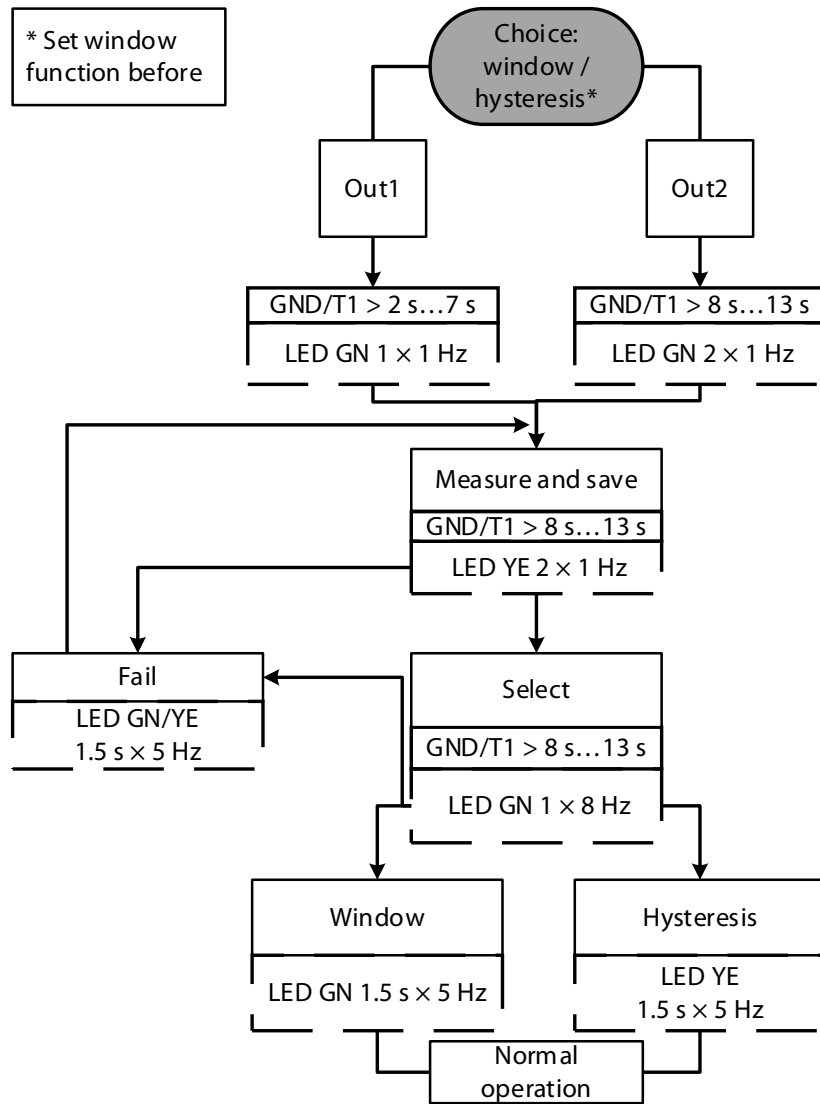

Fig. 35: Window function – switching between hysteresis and window

- ▶ Position the object at any point in the detection range.
- ▶ Press and hold down pushbutton 1 for 8...13 s.
- ▶ Press and hold down pushbutton 1 once more for 8...13 s.
- ⇒ The individual switching point has been taught in successfully if the green LED flashes for 1.5 s at a frequency of 5 Hz.
- ⇒ The hysteresis function has been taught in successfully if the yellow LED flashes for 1.5 s at a frequency of 5 Hz.

### Inverting the output function (NO/NC)

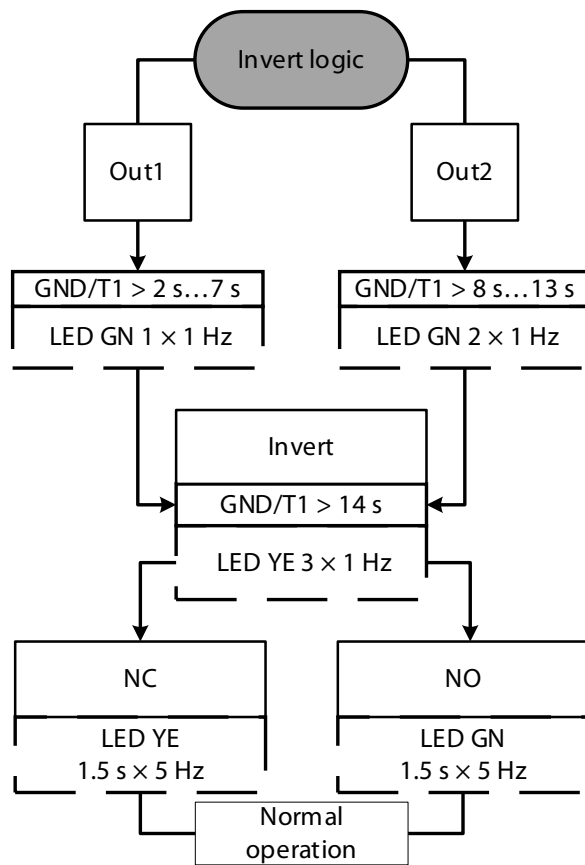

Fig. 36: Inverting the output function (NO/NC)

- ▶ Select the switching output.
- ▶ Press and hold down pushbutton 1 for 14...19 s.
- ⇒ The output function has been successfully inverted as an NO contact if the green LED flashes for 1.5 s at a frequency of 5 Hz.
- ⇒ The output function has been successfully inverted as an NC contact if the yellow LED flashes for 1.5 s at a frequency of 5 Hz.

## Setting operation as a retroreflective sensor

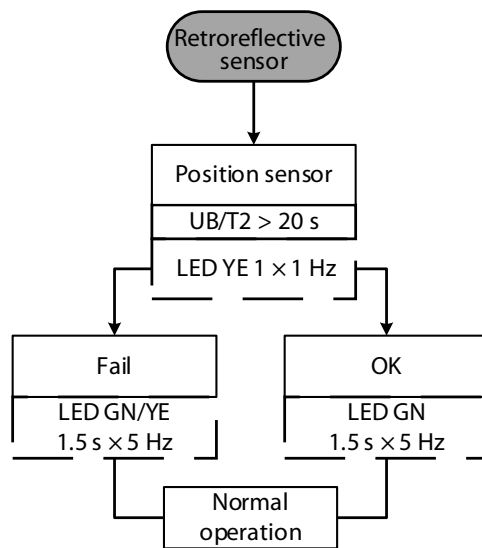

Fig. 37: Setting operation as a retroreflective sensor

- ▶ Position the reflector in the detection range.
- ▶ Press and hold down pushbutton 2 for at least 21 s.
- ⇒ The sensor is set successfully as a retroreflective sensor if the green LED flashes for 1.5 s at a frequency of 5 Hz.

## Reset to factory settings

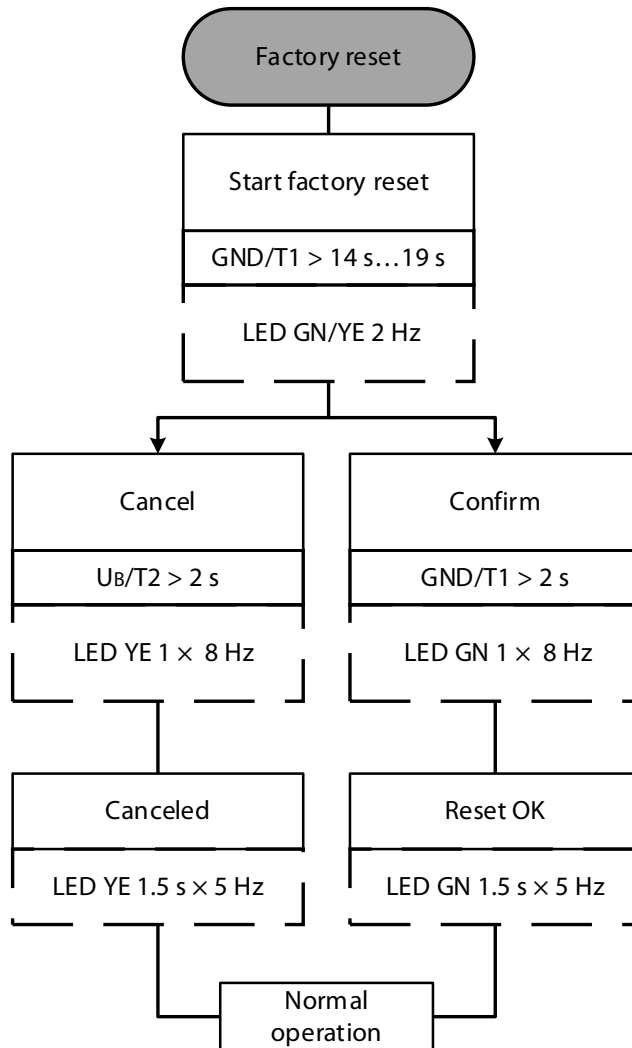

Fig. 38: Reset to factory settings

- ▶ Starting the reset to factory settings: Press and hold down pushbutton 1 for 14...19 s.
- ▶ Confirming the reset to factory settings: Press and hold down pushbutton 1 for 2...7 s.
- ⇒ The device has been successfully reset to the factory settings if the green LED flashes for 1.5 s at a frequency of 5 Hz.

## 10 Troubleshooting

If the device does not function as expected, first check whether ambient interference is present. If there is no ambient interference present, check the connections of the device for faults.

If there are no faults, there is a device malfunction. In this case, decommission the device and replace it with a new device of the same type.

## 11 Maintenance

To improve operation, wipe off dust and dirt from the face of the sonic transducer with a damp cloth.

Ensure that the plug connections and cables are always in good condition.

The devices are maintenance-free, clean dry if required.

## 12 Repair

The device must not be repaired by the user. The device must be decommissioned if it is faulty. Observe our return acceptance conditions when returning the device to Turck.

### 12.1 Returning devices

Returns to Turck can only be accepted if the device has been equipped with a Decontamination declaration enclosed. The decontamination declaration can be downloaded from

<https://www.turck.de/en/retoure-service-6079.php>

and must be completely filled in, and affixed securely and weather-proof to the outside of the packaging.

## 13 Disposal



The devices must be disposed of correctly and must not be included in general household garbage.



## 14 Technical Data

Technical data	RU40...- M18...	RU130...- M18...	RU40...- M30...	RU130...- M30...	RU300...- M30...	RU600...- M30...
Blind zone $S_{\min}$	2.5 cm	15 cm	2.5 cm	15 cm	30 cm	60 cm
Operating range	40 cm	130 cm	40 cm	130 cm	300 cm	600 cm
Opening angle	9°	16°	9°	16°	15°	15°
Ultrasonic frequency	300 kHz	200 kHz	300 kHz	200 kHz	120 kHz	75 kHz
Standard target	20 × 20 mm	100 × 100 mm	20 × 20 mm	100 × 100 mm	100 × 100 mm	100 × 100 mm
Resolution	0.5 mm	1 mm	0.5 mm	1 mm	1 mm	1 mm
Minimum size – switching range	5 mm	10 mm	5 mm	10 mm	25 mm	50 mm
Repetition accuracy	0.15 % full scale					
Temperature deviation	±1.5 % full scale					
Operating voltage	15...30 VDC					
Ripple	10 % $U_{SS}$					
Rated operational current	≤ 150 mA					
No-load current	≤ 50 mA					
Voltage drop	≤ 2.5 V					
Housing	Threaded barrel, CuZn, nickel-plated					
Protection type to EN 60529	IP67					
Conformity with standard	EN 60947-5-2					
Connection type	Male connector, M12 × 1, 5-pin					
Resistance to vibration and mechanical shock	IEC 60068-2					
MTBF value	195 years (SN 29500, Ed. 99...40 °C)					
Operating temperature	-25...+70 °C					
Storage temperature	-40...+80 °C					
Weight	45 g (without pushbuttons)/ 51 g (with pushbuttons)		97 g (without pushbuttons) /105 g (with pushbuttons)			308 g (without pushbut- tons)/ 326 g (with push- buttons)
Switching hysteresis	5 mm	10 mm	5 mm	10 mm	25 mm	≤ 50 mm
Switching frequency	7 Hz	8 Hz	7 Hz	8 Hz	4 Hz	1.6 Hz
Response time	75 ms	65 ms	75 ms	65 ms	125 ms	600 ms
Readiness delay	≤ 300 ms					
Approvals	CE, UL					

## 14.1 Factory settings

<b>Technical data</b>	<b>RU40...-M18...</b>	<b>RU130...-M18...</b>	<b>RU40...-M30...</b>
Output behavior Switching output 1	NO contact	NO contact	NO contact
Switching point output 1	40 cm (end of detection range)	130 cm (end of detection range)	40 cm (end of detection range)
Output behavior Switching output 2	NO contact	NO contact	NO contact
Switching point output 2	40 cm (end of detection range)	130 cm (end of detection range)	40 cm (end of detection range)

<b>Technical data</b>	<b>RU130...-M30...</b>	<b>RU300...-M30...</b>	<b>RU600...-M30...</b>
Output behavior Switching output 1	NO contact	NO contact	NO contact
Switching point output 1	130 cm (end of detection range)	300 cm (end of detection range)	600 cm (end of detection range)
Output behavior Switching output 2	NO contact	NO contact	NO contact
Switching point output 2	130 cm (end of detection range)	300 cm (end of detection range)	600 cm (end of detection range)

## 15 Turck Subsidiaries - Contact Information

<b>Germany</b>	Hans Turck GmbH & Co. KG Witzlebenstraße 7, 45472 Mülheim an der Ruhr <a href="http://www.turck.de">www.turck.de</a>
<b>Australia</b>	Turck Australia Pty Ltd Building 4, 19-25 Duerdin Street, Notting Hill, 3168 Victoria <a href="http://www.turck.com.au">www.turck.com.au</a>
<b>Belgium</b>	TURCK MULTIPROX Lion d'Orweg 12, B-9300 Aalst <a href="http://www.multiprox.be">www.multiprox.be</a>
<b>Brazil</b>	Turck do Brasil Automação Ltda. Rua Anjo Custódio Nr. 42, Jardim Anália Franco, CEP 03358-040 São Paulo <a href="http://www.turck.com.br">www.turck.com.br</a>
<b>China</b>	Turck (Tianjin) Sensor Co. Ltd. 18,4th Xinghuazhi Road, Xiqing Economic Development Area, 300381 Tianjin <a href="http://www.turck.com.cn">www.turck.com.cn</a>
<b>France</b>	TURCK BANNER S.A.S. 11 rue de Courtalin Bat C, Magny Le Hongre, F-77703 MARNE LA VALLEE Cedex 4 <a href="http://www.turckbanner.fr">www.turckbanner.fr</a>
<b>Great Britain</b>	TURCK BANNER LIMITED Blenheim House, Hurricane Way, GB-SS11 8YT Wickford, Essex <a href="http://www.turckbanner.co.uk">www.turckbanner.co.uk</a>
<b>India</b>	TURCK India Automation Pvt. Ltd. 401-403 Aurum Avenue, Survey. No 109 /4, Near Cummins Complex, Baner-Balewadi Link Rd., 411045 Pune - Maharashtra <a href="http://www.turck.co.in">www.turck.co.in</a>
<b>Italy</b>	TURCK BANNER S.R.L. Via San Domenico 5, IT-20008 Bareggio (MI) <a href="http://www.turckbanner.it">www.turckbanner.it</a>
<b>Japan</b>	TURCK Japan Corporation Syuuhou Bldg. 6F, 2-13-12, Kanda-Sudacho, Chiyoda-ku, 101-0041 Tokyo <a href="http://www.turck.jp">www.turck.jp</a>
<b>Canada</b>	Turck Canada Inc. 140 Duffield Drive, CDN-Markham, Ontario L6G 1B5 <a href="http://www.turck.ca">www.turck.ca</a>
<b>Korea</b>	Turck Korea Co, Ltd. B-509 Gwangmyeong Technopark, 60 Haan-ro, Gwangmyeong-si, 14322 Gyeonggi-Do <a href="http://www.turck.kr">www.turck.kr</a>
<b>Malaysia</b>	Turck Banner Malaysia Sdn Bhd Unit A-23A-08, Tower A, Pinnacle Petaling Jaya, Jalan Utara C, 46200 Petaling Jaya Selangor <a href="http://www.turckbanner.my">www.turckbanner.my</a>

<b>Mexico</b>	Turck Comercial, S. de RL de CV Blvd. Campestre No. 100, Parque Industrial SERVER, C.P. 25350 Arteaga, Coahuila <a href="http://www.turck.com.mx">www.turck.com.mx</a>
<b>Netherlands</b>	Turck B. V. Ruiterlaan 7, NL-8019 BN Zwolle <a href="http://www.turck.nl">www.turck.nl</a>
<b>Austria</b>	Turck GmbH Graumanngasse 7/A5-1, A-1150 Wien <a href="http://www.turck.at">www.turck.at</a>
<b>Poland</b>	TURCK sp.z.o.o. Wroclawska 115, PL-45-836 Opole <a href="http://www.turck.pl">www.turck.pl</a>
<b>Romania</b>	Turck Automation Romania SRL Str. Siriului nr. 6-8, Sector 1, RO-014354 Bucuresti <a href="http://www.turck.ro">www.turck.ro</a>
<b>Russian Federation</b>	TURCK RUS OOO 2-nd Pryadilnaya Street, 1, 105037 Moscow <a href="http://www.turck.ru">www.turck.ru</a>
<b>Sweden</b>	Turck Sweden Office Fabriksstråket 9, 433 76 Jonsered <a href="http://www.turck.se">www.turck.se</a>
<b>Singapore</b>	TURCK BANNER Singapore Pte. Ltd. 25 International Business Park, #04-75/77 (West Wing) German Centre, 609916 Singapore <a href="http://www.turckbanner.sg">www.turckbanner.sg</a>
<b>South Africa</b>	Turck Banner (Pty) Ltd Boeing Road East, Bedfordview, ZA-2007 Johannesburg <a href="http://www.turckbanner.co.za">www.turckbanner.co.za</a>
<b>Czech Republic</b>	TURCK s.r.o. Na Brne 2065, CZ-500 06 Hradec Králové <a href="http://www.turck.cz">www.turck.cz</a>
<b>Turkey</b>	Turck Otomasyon Ticaret Limited Sirketi Inönü mah. Kayisdagi c., Yesil Konak Evleri No: 178, A Blok D:4, 34755 Kadiköy/ Istanbul <a href="http://www.turck.com.tr">www.turck.com.tr</a>
<b>Hungary</b>	TURCK Hungary kft. Árpád fejedelem útja 26-28., Óbuda Gate, 2. em., H-1023 Budapest <a href="http://www.turck.hu">www.turck.hu</a>
<b>USA</b>	Turck Inc. 3000 Campus Drive, USA-MN 55441 Minneapolis <a href="http://www.turck.us">www.turck.us</a>

# TURCK

Over 30 subsidiaries and over  
60 representations worldwide!

100031796 | 2021/06



[www.turck.com](http://www.turck.com)